

MEMORANDUM

TO: South Texas Water Authority Board of Directors
FROM: Jose M. Graveley, President
DATE: September 4, 2023
SUBJECT: Public Hearing Notice and Agenda for the South Texas Water Authority

A public hearing of the STWA Board of Directors is scheduled for:

Tuesday, September 12, 2023

5:30 p.m.

South Texas Water Authority
2302 East Sage Road
Kingsville, Texas

Agenda

1. Call to order.
2. Public Hearing on **proposed** \$0.070374 per \$100 valuation tax rate for Fiscal Year 2024/Tax Year 2023.
3. Public Comment.
4. Adjournment.

BB/JM/fdl

This meeting notice was posted on
STWA's website, www.stwa.org, and on
indoor and outdoor bulletin boards at
STWA's administrative offices,
2302 East Sage Road, Kingsville, Texas at
2:30 am/pm on September 8, 2023
frances Garcia
Assistant Secretary

MEMORANDUM

TO: South Texas Water Authority Board of Directors
FROM: Jose M Graveley, President
DATE: September 4, 2023
SUBJECT: Meeting Notice and Agenda for the South Texas Water Authority

A Regular Meeting of the STWA Board of Directors is scheduled for:

Tuesday, September 12, 2023

Immediately following the 5:30 p.m. STWA Public Hearing
South Texas Water Authority
2302 East Sage Road, Kingsville, Texas

The Board will consider and act upon any lawful subject which may come before it, including among others, the following:

Agenda

1. Call to order.
2. Citizen comments. This is an opportunity for citizens to address the Board of Directors concerning an issue of community interest that is not on the agenda. Comments on the agenda items must be made when the agenda item comes before the Board. The President may place a time limit on all comments. The response of the Board to any comment under this heading is limited to making a statement of specific factual information in response to the inquiry, or, reciting existing policy in response to the inquiry. Any deliberation of the issue is limited to a proposal to place it on the agenda for a later meeting.
3. Presentation from ICE regarding ongoing projects. (Attachment 1)
4. Approval of Minutes. (Attachment 2)
5. Quarterly Report/Treasurer's Report/Payment of Bills. (Attachment 3)
6. Fiscal Year 2024 budget, revenues and rates. (Attachment 4)
7. **Resolution 23-22.** Resolution adopting the recommended Fiscal Year 2024 budget. (Attachment 5)
8. **Resolution 23-23.** Resolution adopting the Fiscal Year 2024/Tax Year 2023 tax rate. (Attachment 6)
9. Letter of Engagement with John Womack and Company, P.C. for Independent Auditor Services for FY 2023. (Attachment 7)
10. Bids for 2023 or 2024 half-ton pickup truck to replace damaged 2019 Ford F-150 4x4 truck. (Attachment 8)

11. Bids for purchase of compact track loader. (Attachment 9)
12. **Resolution 23-24.** Resolution awarding the bid for the purchase of one compact track loader. (Attachment 10)
13. Administration Report.
14. Adjournment.

The Board may go into closed session at any time when permitted by Chapter 551, Government Code. Before going into closed session, a quorum of the Board must be assembled in the meeting room, the meeting must be convened as an open meeting pursuant to proper notice, and the presiding officer must announce that a closed session will be held and must identify the sections of Chapter 551, Government Code, authorizing the closed session.

JMG/JM/fdl
Attachments

This meeting notice was posted on
STWA's website, www.stwa.org, and on
indoor and outdoor bulletin boards at
STWA's administrative offices,
2302 East Sage Road, Kingsville, Texas at
2:30 am/pm on September 8, 2023
Francis DeLeon
Assistant Secretary

ATTACHMENT 1

Ongoing Projects

Information will be provided at the meeting.

ATTACHMENT 2

Approval of Minutes

SOUTH TEXAS WATER AUTHORITY
Regular Board of Directors Meeting
August 8, 2023
Minutes

Board Members Present:

Jose Graveley
Frances Garcia
Imelda Garza
Rudy Galvan, Jr.
Kathleen Lowman
Joe Morales
Patsy Rodgers
Arturo Rodriguez

Board Members Absent:

Angela Pena

Staff Present:

John Marez
Frances De Leon
Jo Ella Wagner
Nigel Gomez
Patrick Sendejo

Guests Present:

Ivan Luna, I.C.E.
Rogelio Rodriguez, Water Finance Exchange
Terry Arnold, Seven Seas
Bill Flickinger, Willatt & Flickinger (Zoom)
Christopher Williams, Raftelis (Zoom)

1. Call to Order.

Mr. Jose Graveley, Board President, called the Regular Meeting of the STWA Board of Directors to order at 5:33 p.m. A quorum was present.

2. Citizen Comments.

Mr. Graveley opened the floor to citizen's comments. No comments were made.

The order of the agenda was changed to accommodate the guests.

11. Approval of Rate Study by Raftelis.

Mr. Marez presented a Water Rate and Financial Plan Study proposal from Raftelis. He explained that NewGen Strategies previously provided the annual review of the City of Corpus Christi's rate model until NewGen was hired by the City in 2022 to conduct their rate study. Expergy was then contacted to continue NewGen's work but never produced a report so the Authority then contacted Raftelis, a company recommended by STWA's consultants at Water Finance Exchange.

Mr. Christopher William, senior consultant with Raftelis, explained that the proposal includes three phases: a review of the Corpus Christi rate model, an Industrial Customer Study, and a Rate and Financial Planning Study. Ms. Wagner added that the cost for Phase 1 would be split with San Patricio Municipal Water District. Mr. Morales stated that he was in favor of Phase 1 but had concerns about the other two phases. He made a motion to approve \$5,060 for Phase 1, Mr. Graveley seconded and all voted in favor. Mr. Galvan made a motion to meet no later than

October to consider adding Phase 2. After further discussion Ms. Lowman made a motion to approve Phase 2. Ms. Rodgers seconded the motion which passed on a 7 to 1 vote with Mr. Morales voting against.

Mr. Rodriguez of Water Finance Exchange commented that the State of Texas opens up funding in November and he believes it would be advantageous to have STWA's Master Plan and Rate Study in place. Mr. Williams noted that completion of the plan would take two to three months.

12. Third Amendment to Amended and Restated Water Supply Contract Between South Texas Water Authority and Nueces Water Supply Corporation.

Mr. Marez stated that in April 2022, TCEQ conducted an investigation of the Nueces Water Supply Corporation and noted an alleged violation pertaining to the total storage capacity at the Central Pressure Plane. Under the current water supply contract, Nueces WSC owns up to the amount of 200 gallons per connection for 300 connections but because there are now more than 300 connections in the Central Pressure Plane, the contract requires an amendment in order to provide a sufficient amount of storage capacity.

13. Resolution 23-20. Resolution approving the Third Amendment to Amended and Restated Water Supply Contract Between the South Texas Water Authority and Nueces Water Supply Corporation.

Mr. Morales made a motion to adopt Resolution 23-20 approving the Third Amendment to the Amended and Restated Water Supply Contract between South Texas Water Authority and Nueces Water Supply Corporation. Mr. Galvan seconded. The motion passed by unanimous vote.

16. Non-Binding Agreement with SSW.

Mr. Marez presented a Brackish Water Supply for South Texas Water Authority Confidential Term Sheet for the Board's consideration. Mr. Terry Arnold of Seven Seas Water informed the Board that the City of Alice is building a desalination plant and ground breaking is expected to occur at the end of September. Following questions from Mr. Morales about whether STWA's enabling legislation allows this type of project, Mr. Bill Flickinger advised that he has reviewed the Term Sheet and the enabling legislation gives authority to enter into this type of contract. Mr. Galvan made a motion to approve the agreement. Ms. Garza seconded. All voted in favor.

3. Approval of Minutes.

Ms. Rodgers made a motion to approve the minutes of the August 1, 2023 Public Hearing and the August 1, 2023 Regular Meeting as presented. Mr. Galvan seconded. The motion passed by unanimous vote.

4. Quarterly Report/Treasurer's Report/Payment of Bills.

The Quarterly Report was not presented. The following reports were presented for the Board's consideration:

Treasurer's Report for period ending April 30, 2023
Revenue Fund Income Statement for period ending April 30, 2023
Tax Fund Income Statement for period ending April 30, 2023
Special Services Income Statement for period ending April 30, 2023
STWA Revenue Fund Balance Sheet – April 30, 2023
STWA Revenue Fund Trial Balance for April, 2023
STWA Debt Service Fund Income Statement for period ending April 30, 2023
STWA Debt Service Fund Balance Sheet – April 30, 2023
STWA Debt Service Fund Trial Balance – April, 2023
STWA Capital Projects Fund Income Statement for period ending April 30, 2023
STWA Capital Projects Fund Balance Sheet – April 30, 2023
STWA Capital Projects Fund Trial Balance – April, 2023
Treasurer's Report for period ending May 31, 2023
Revenue Fund Income Statement for period ending May 31, 2023
Tax Fund Income Statement for period ending May 31, 2023
Special Services Income Statement for period ending May 31, 2023
STWA Revenue Fund Balance Sheet – May 31, 2023
STWA Revenue Fund Trial Balance for May, 2023
STWA Debt Service Fund Income Statement for period ending May 31, 2023
STWA Debt Service Fund Balance Sheet – May 31, 2023
STWA Debt Service Fund Trial Balance – May, 2023
STWA Capital Projects Fund Income Statement for period ending May 31, 2023
STWA Capital Projects Fund Balance Sheet – May 31, 2023
STWA Capital Projects Fund Trial Balance – May, 2023
STWA 2012 Bond Election Report
Anticipated vs Actual Water Rate Charged and Net Revenue Worksheets

The following invoices were presented for Board approval:

• International Consulting Engineers	\$ 22,586.20
• International Consulting Engineers	\$ 47,511.40
• International Consulting Engineers	\$ 13,877.40

Ms. Wagner asked that the Board disregard the invoice in the agenda packet because there have been some changes and that invoice will not be paid. She instead presented these three invoices. Mr. Galvan made a motion to approve the Treasurer's Report, and payment of the bills as presented. Ms. Garza seconded and all voted in favor.

5. Review of 2023 Certified Appraisal Rolls for the Authority's district in Kleberg and Nueces Counties.

The Board reviewed the Certified Appraisal Rolls from Kleberg County Appraisal District and Nueces County Appraisal District. The KCAD appraisal roll reflects a final certified value of \$1,548,931,070 and the NCAD final certified value is \$1,451,331,625. These values reflect a total increase of \$305,073,846 over last year's values. Mr. Marez requested approval of Resolutions 23-18 and 23-19 adopting the appraisal rolls.

6. Resolution 23-18. Resolution adopting the appraisal roll for the South Texas Water Authority's district in Kleberg County for tax year 2023.

After reviewing the Kleberg County appraisal roll for tax year 2023, Ms. Rodgers made a motion to approve Resolution 23-18. Mr. Galvan seconded the motion. The motion carried.

7. Resolution 23-19. Resolution adopting the appraisal roll for the South Texas Water Authority's district in Nueces County for tax year 2023.

Following review of the Nueces County appraisal roll for tax year 2023, Ms. Rodgers made a motion to approve Resolution 23-19. Mr. Galvan seconded the motion. The motion passed by unanimous vote.

8. Preliminary Fiscal Year 2024 Budget.

Ms. Wagner reviewed the preliminary Fiscal Year 2024 Budget. She stated that she and Mr. Marez met with most of the Board members and based on those discussions, this budget is the highest option that was presented at those meetings. The budget includes a 4% wage increase for all employees including managers and a mini track hoe has been included under Capital Outlay. The projected Revenue Fund Net Income is \$257,325. She added that the budget will need to be sent to STWA's wholesale customers for their review and comments. Mr. Morales made a motion to authorize staff to send the preliminary 2024 budget to the wholesale customers. Mr. Galvan seconded and all voted in favor.

9. Proposed Fiscal Year 2024/Tax Year 2023 tax rate and authorization to publish notice of public hearing.

Ms. Wagner presented the Water District Notice of Public Hearing on Tax Rate reflecting a proposed total tax rate of \$0.070374/\$100 valuation comprised of a Maintenance & Operation tax rate of \$0.058044/\$100 and an Interest & Sinking tax rate of \$0.012330. The proposed total tax rate is \$0.000001 lower than the tax rate calculated on the average home value in order to remain below the 3.5% allowed increase. Mr. Galvan made a motion to authorize staff to publish the Water District Notice of Public Hearing on Tax Rate. Ms. Garza seconded. All members present voted in favor.

STWA Regular Meeting Minutes

August 8, 2023

Page 5

10. Letter of Engagement with John Womack and Company, P.C. for Independent Auditor Services for FY 2023.

Ms. Wagner stated that as a result of GASB changes that are under review by John Womack and Company, the engagement letter will be presented at the next meeting.

14. Conservation and Reclamation Districts Ballot for Election of Board of Directors for the Kleberg County Appraisal District.

Mr. Marez presented the Kleberg County Appraisal District ballot and Resolution 23-21 and explained that the Authority is being asked to formally submit votes. Ms. Garcia is listed as STWA's nominee.

15. Resolution 23-21. Resolution casting the South Texas Water Authority's votes for Conservation and Reclamation Districts for Election of Kleberg County Appraisal District Board of Directors.

Mr. Galvan made a motion to cast all votes for Ms. Garcia. Ms. Garza seconded. The motion passed by unanimous vote.

17. Administration Report.

Mr. Marez reported that staff will meet with Corpus Christi Water on Thursday regarding Tesla, water needs and the water supply contract. Additionally, work continues on the STWA Master Plan.

18. Adjournment.

With no further business to discuss, Mr. Rodriguez made a motion to adjourn the meeting at 7:07 p.m. Mr. Galvan seconded. All voted in favor.

Respectfully submitted,

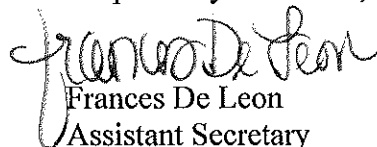
Frances De Leon
Assistant Secretary

ATTACHMENT 3

Quarterly Report/Treasurer's Report/Payment of Bills

These reports are not available but will be provided under separate cover prior to the meeting.

ATTACHMENT 4

FY 2024 Budget

CORRECTED
Memo

To: South Texas Water Authority Board of Directors
From: John Marez, Exec Dir/Admin
Date: September 8, 2023
Re: Fiscal Year 2024 Budget, Revenue and Rates

Background:

Enclosed please find the Final Draft Fiscal Year 2024 Budget, including a General Fund Budget, Tax Fund Budget, Special Services Fund Budget, Debt Service Fund Budget, and Capital Project Fund Budget. The budgets are based on the following:

- Handling Charge of \$0.50 per 1000 gallons,
- M&O Tax Rate of \$0.058044 per \$100 valuation - a decrease of \$0.006868,
- I&S Tax Rate of \$0.012330 per \$100 valuation, a decrease of \$0.001247 due to a lower debt service requirement and higher tax base,
- The Total Tax Rate (combined M&O and I&S) is a decrease of \$0.008115,
- A proposed 46¢ increase in the Cost of Water from the City of Corpus Christi of \$2.77 per 1,000 gallons - a cost that is passed through to STWA's Wholesale Customers,
- An overall payroll adjustment of approximately 4% for all STWA employees and milestone raises per Board policy. The total annual cost distributed as follows: STWA - \$22,932, NWSC - \$20,804 and RWSC - \$21,150,
- Capital purchases of \$280,500,

Analysis:

The budget results in a positive ending balance of \$249,543. As stated in last year's memo on budget adoption, any remaining funds will be added to the Reserve balance and will be used to address future infrastructure needs including extending the life of the 42" waterline.

The Interest and Sinking (I&S) tax rate is based on the debt service schedule and calculated to generate the required funds to pay the annual interest and principal on the bonds.

The proposed Special Services Fund Budget is the approximate cost to recoup the cost of providing turn-key management and operation services for the Nueces and Ricardo Water Supply Corporations.

As the Board is aware, the Capital Project Fund Budget is based on the remaining funds from the \$5.1M in bonds issued to address the relocation of the 42" line at US 77/I-69 and CR 36, the Kingsville Pump Station Improvements and Bishop Pump Station Improvements. Since the projects were completed under budget, additional improvements to the Regional System have been made, such as the installation of an emergency generator for the Kingsville PS, assessments on the 42" waterline, conversion of the Driscoll Booster Station from a chlorination booster to a chloramine booster station, and funds paid on the new Banquete Pump Station project. An ongoing project is the installation of additional anodes on the 42" line and installing additional rectifier stations. The

STWA FY 2024 CHANGES TO FUND BALANCE

BEGINNING BALANCE	REVENUES	EXPENSES	NET INCOME & BALANCE
General/ Revenue Fund \$5,131,198	Water Revenue (Pass thru) \$1,489,786	Cost of Corpus Christi Water \$1,489,786	FY 2024 Net Income/(Loss) \$249,543
Direct Delivery Water Cost \$2.77000	Handling Charge Revenue \$277,916	Water Loss \$0	END FUND BALANCE \$5,380,741
	Premium Incremental Increase/O & M Fees \$23,300		
Handling Charge \$0.500000	Interest Rev. Incl. Driscoll \$220,175	M & O/Administrative \$1,666,073	
	Special Services Fees \$920,979	Special Services Expenses \$920,979	
	Misc, Tax Sur & Asset Disp \$24,000	Capital Outlay/Acquisition \$280,500	
	Transfer from Tax Fund \$1,650,724		
	Total General Revenues \$4,606,881	Total Expenses \$4,357,338	
M&O Tax Fund \$0	M&OTax Revenues \$1,659,615	Transfer to Revenue Fund \$1,650,724	Tax Fund \$0
Tax Base Value \$3,000,262,695	M&O Delinquent Taxes + P&I \$63,000	Appraisal Districts \$11,264	
Kleberg County \$1,548,931,070	Interest Earned \$0	Tax Collector's Fees \$60,627	
Nueces County \$1,451,331,625	Transfer from Reserve Fund \$0	Miscellaneous \$0	
95.30%	Miscellaneous \$0	Total Expenses \$1,722,615	
M&O Tax Rate @ \$0.058044	Total M&O Tax Fund Revenue \$1,722,615		
I&S Tax Fund \$118,828	I &STax Revenues \$369,941	Transfer to Revenue Fund \$0	I&S Tax Fund Est. Balance \$142,999
Tax Base Value \$3,000,262,695	I&S Delinquent Taxes + P&I \$14,000	Appraisal Districts \$6,014	
Kleberg County \$1,548,931,070	Interest Earned \$9,000	Tax Collector's Fees \$14,927	
Nueces County \$1,451,331,625	Transfer from Reserve Fund \$0	Principal, Interest, Fiscal Fees \$349,200	
100.00%	Fee in Lieu of Taxes \$1,370	Total Expenses \$370,141	
I&STax Rate @ \$0.012330	Total I&S Tax Fund Revenue \$394,311	Financing Sources Over (Under) \$24,171	

SOUTH TEXAS WATER AUTHORITY
 PROPOSED FY 2024 BUDGET
 General Fund

CC Water Cost
 \$2.77000
 Handling Charge
 \$0.500000
 M&O Tax Rate
 \$0.058044
 I&S Tax Rate
 \$0.012330

PROPOSED
 FY 2024
 Budget

REVENUES

Water Service Revenues	\$1,489,786
Handling Charge Revenue	\$277,916
Premium Incremental Increase	\$10,800
Fee in Lieu of Taxes	\$10,500
Interest on Temp. Invest.	\$220,000
Interest Note - City of Driscoll	\$175
Other Revenue	
Operations & Maintenance Fees	\$12,500
Miscellaneous Revenues	\$12,000
 TOTAL REVENUES	 \$2,033,678

EXPENDITURES

Water Service Expenditures:	
Bulk Water Purchases	\$1,489,786
Water Loss	\$0
 TOTAL WATER SERVICE	 \$1,489,786

Payroll Costs

Salaries & Wages -	
Permanent Employees	\$397,635
Vacation Buy Back	\$8,500
Part-Time Employee	\$4,368
Overtime - NWSC	\$0
Stand-by Pay - NWSC	\$0
Overtime - RWSC	\$0
Stand-by Pay - RWSC	\$0
Overtime - STWA	\$15,000
Stand-by Pay - STWA	\$1,300
Employee Retirement Premiums	\$68,713
Group Insurance Premium	\$243,522
Unemployment Compensation	\$70
Workers' Compensation	\$6,436
Hospital Insurance Tax	\$6,029
 TOTAL PERSONNEL	 \$751,573

Supplies & Materials

Repairs & Maintenance	\$150,000
Meter Expense	\$5,000
Tank Repairs	\$30,000
Major Repairs	\$25,000
 TOTAL SUPPLIES & MATERIALS	 \$210,000

Other Operating Expenditures:

Professional Fees	
Legal	\$40,000
Auditing	\$10,500
Engineering	\$50,000
Management & Consulting	\$25,000
JMAR Management Consulting, LLC	\$70,000
Inspection	\$7,500
TOTAL PROFESSIONAL FEES	\$203,000

Consum Supplies/Materials

Postage	\$8,500
Printing/Office Supplies	\$37,500
Janitorial/Site Maintenance	\$19,000
Fuel/Lubricants/Repairs	\$85,000
Chemicals/Water Samples	\$60,000
Safety Equipment	\$2,000
Small Tools	\$3,000
TOTAL CONSUM SUPPLIES/MATERIALS	\$215,000

Recurring Operating Costs

Telephone/Communications	\$40,000
Utilities	\$122,500
D & O Liability Insurance	\$3,500
Property Insurance	\$48,000
General Liability	\$5,500
Auto Insurance	\$3,100
Travel/Training/Meetings - Staff	\$15,000
Travel/Training/Meetings - Board of Directors	\$10,000
Travel/Training/Meetings - Legislation	\$0
Rental-Equipment/Uniforms	\$6,000
Dues/Subscriptions/Publications	\$17,500
Pass Through Costs	\$400
TOTAL RECURRING OPER. COSTS	\$271,500

Miscellaneous

Miscellaneous Expenditures	\$15,000
TOTAL MISCELLANEOUS	\$15,000

Total Administrative & Operations Exp.	\$3,155,859	\$1,666,073
--	-------------	-------------

Capital Outlay

Capital Acquisition	\$230,500
Engineering	\$50,000
TOTAL CAPITAL OUTLAY	\$280,500

TOTAL EXPENDITURES (w/o D.S. exp.)	\$3,436,359
---	--------------------

Excess (Deficiencies) of Revenue Over Expenditures	(\$1,402,682)
---	---------------

OTHER FINANCE SOURCES (USES)

Transfer to Other Funds	
Disposition of Assets (Surplus Sale)	\$1,500
Transfer from Tax Fund	\$1,650,724
TOTAL OTHER FINANCING SOURCES (USES)	\$1,652,224
EXCESS (DEFICIENCIES) OF REVENUES OVER OTHER SOURCES (USED)	\$249,542
NET INCOME	\$249,542

2024 Proposed Capital Acquisitions	
\$115,000	2 trucks
\$5,500	technology upgrades
\$30,000	fencing @ pump stations
<u>\$80,000</u>	mini trackhoe
\$230,500	
\$50,000	Engineering/Architecture New Office Building
\$280,500	Budgeted Capital Acquisitions

SOUTH TEXAS WATER AUTHORITY
 PROPOSED FY 2024 BUDGET
 M & O TAX FUND

CC Water Cost
 \$2.77000
 Handling Charge
 \$0.500000
 M&O Tax Rate
 \$0.058044
 I&S Tax Rate
 \$0.012330

PROPOSED
 FY 2024

REVENUES	Budget
Ad Valorem - Current (M&O)	\$1,659,615
Delinquent Taxes	\$37,000
Penalty & Interest - Tax Accounts (M&O)	\$26,000
TOTAL M&O TAX REVENUES	\$1,722,615
EXPENDITURES	
Tax Collector Fees	\$60,627
Appraisal Districts	\$11,264
Refunds	\$0
TOTAL EXPENDITURES	\$71,891
REVENUES OVER EXPENDITURES	\$1,650,724
OTHER USES	
Transfer to Revenue Fund (Tax)	\$1,650,724
TOTAL EXPEND. & OTHER USES	\$1,722,615
 Excess Revenues and Other Financing Sources Over (Under) Expenditures and Other Uses	 \$0

SOUTH TEXAS WATER AUTHORITY
PROPOSED FY 2024 BUDGET
Special Services

RWSC - 1101 customers
NWSC - 1083 customers

CC Water Cost
\$2.77000
Handling Charge
\$0.500000
M&O Tax Rate
\$0.058044
I&S Tax Rate
\$0.012330

PROPOSED
FY 2024
Budget

REVENUES

Ricardo Water Supply Corporation
Nueces Water Supply Corporation

\$464,285
\$456,694

TOTAL SPECIAL SERVICES REVENUE

\$920,979

EXPENDITURES

Personnel
Overhead
Administrator

\$460,842
\$430,137
\$30,000

TOTAL EXPENDITURES

\$920,979

REVENUES OVER EXPENDITURES

\$0

SOUTH TEXAS WATER AUTHORITY
 PROPOSED FY 2024 BUDGET
 I&S TAX FUND

CC Water Cost
 \$2.77000
 Handling Charge
 \$0.500000
 M&O Tax Rate
 \$0.058044
 I&S Tax Rate
 \$0.012330

PROPOSED
 FY 2024
 Budget

REVENUES

Ad Valorem - Current (M&O)	\$369,941
Delinquent Taxes	\$9,000
Out of District - Fee in Lieu of Taxes - NCWCID#5	\$1,370
Penalty & Interest - Tax Accounts (M&O)	\$5,000
Interest on Temporary Investments	\$9,000
 TOTAL M&O TAX REVENUES	 \$394,311

EXPENDITURES

Fiscal Agent Fees	\$200
Bond Interest Expense	\$94,000
Bond Principal Payments	\$255,000
Tax Collector Fees	\$14,927
Appraisal Districts	\$6,014
Refunds	\$0
 TOTAL EXPENDITURES	 \$370,141

REVENUES OVER EXPENDITURES	\$24,171
----------------------------	----------

TOTAL EXPEND. & OTHER USES	\$370,141
----------------------------	-----------

Excess Revenues and Other Financing Sources Over (Under) Expenditures and Other Uses	\$24,171
--	----------

**SOUTH TEXAS WATER AUTHORITY
FY 2024 PROPOSED BUDGET
CAPITAL PROJECT FUND**

Cost of Bond Issuance: \$107,386.40
Proposition #1: REGIONAL WATERLINE \$1,900,000.00
Proposition #2: KINGSVILLE PUMP STATION \$2,925,000.00
Proposition #3: BISHOP FACILITY \$375,000.00

\$5,307,386.40

	2013, 2014, 2015, 2016, 2017	2019	2020	2021	2022	2023	2023	2024
	REVENUE & EXPEND.	REVENUE & EXPEND.	REVENUE & EXPEND.	REVENUE & EXPEND.	REVENUE & EXPEND.	REVENUE & EXPEND.	PRELIMINARY FINAL BUDGET	PROPOSED BUDGET
REVENUES						5/31/2023		
Bond Proceeds	\$5,307,386.40	\$0.00	\$0.00	\$0.00	\$0.00	\$0.00	\$0.00	\$0.00
Interest Earnings	\$25,670.46	\$22,436.25	\$7,767.88	\$268.66	\$2,540.00	\$11,114.00	\$16,250.00	\$9,500.00
Other Income	<u>\$7,167.00</u>	<u>\$0.00</u>	<u>\$9,816.38</u>	<u>\$0.00</u>	<u>\$0.00</u>	<u>\$0.00</u>	<u>\$0.00</u>	<u>\$0.00</u>
Total Revenue and Other Financing Sources	\$5,340,223.86	\$22,436.25	\$17,584.26	\$268.66	\$2,540.00	\$11,114.00	\$16,250.00	\$9,500.00
EXPENDITURES								
Right of Way Acquisition	\$57,436.00	\$0.00	\$0.00	\$0.00	\$0.00	\$0.00	\$0.00	\$0.00
Engineering Fees	\$691,406.00	\$0.00	\$0.00	\$2,175.00	\$0.00	\$0.00	\$0.00	\$0.00
Construction Costs	\$3,114,739.60	\$6,441.00	\$0.00	\$305,000.00	\$0.00	\$0.00	\$0.00	\$0.00
42" Line - Cathodic Protection	\$0.00	\$149,872.34	\$147,846.80	\$120,910.00	\$9,172.10	\$23,170.00	\$50,000.00	\$269,855.09
Pipeline Condition Assessment	\$100,605.00	\$0.00	\$0.00	\$0.00	\$0.00	\$0.00	\$0.00	\$0.00
Legal & Administrative Fees	\$61,988.00	\$0.00	\$0.00	\$0.00	\$0.00	\$0.00	\$0.00	\$0.00
Cost of Bond Issuance	\$98,669.00	\$0.00	\$0.00	\$0.00	\$0.00	\$0.00	\$0.00	\$0.00
Miscellaneous Fees	<u>\$0.00</u>	<u>\$0.00</u>	<u>\$4,369.00</u>	<u>\$0.00</u>	<u>\$0.00</u>	<u>\$0.00</u>	<u>\$0.00</u>	<u>\$0.00</u>
TOTAL EXPENDITURES	\$4,124,843.60	\$156,313.34	\$152,215.80	\$428,085.00	\$9,172.10	\$23,170.00	\$50,000.00	\$269,855.09
TOTAL EXPEND. & OTHER USES	\$4,124,843.60	\$156,313.34	\$152,215.80	\$428,085.00	\$9,172.10	\$23,170.00	\$50,000.00	\$269,855.09
Excess Bond Proceeds/ Transfer to Debt Service to use toward first Debt Service payment.	\$8,717.50	\$0.00	\$0.00	\$0.00	\$0.00	\$0.00	\$0.00	\$0.00
Total Financing Expenditures	\$3,655,631.83	\$156,313.34	\$152,215.80	\$428,085.00	\$9,172.10	\$23,170.00	\$50,000.00	\$269,855.09
Excess Revenues and Other Financing Sources Over (Under) Expenditures and Other Uses	\$1,684,592.03	-\$133,877.09	-\$134,631.54	-\$427,816.34	-\$6,632.10	-\$12,056.00	-\$33,750.00	-\$260,355.09
FUND BALANCE	\$1,684,592.03	\$856,552.97	\$721,921.43	\$294,105.09	\$287,472.99	\$275,416.99	\$260,355.09	\$0.00

ATTACHMENT 5

Resolution 23-22

SOUTH TEXAS WATER AUTHORITY
Resolution 23-22

RESOLUTION ADOPTING THE RECOMMENDED FISCAL YEAR 2024 BUDGET.

WHEREAS, the South Texas Water Authority is required to adopt a budget for each fiscal year,
and

WHEREAS, with the adoption of this budget, the Authority adopts the following Handling Charge
and *estimated* Water Rate for Customers:

A Handling Charge of 50¢ per thousand gallons PLUS the cost of water purchased from the City of
Corpus Christi which is based on *estimated* monthly sales volume as follows:

Month	ESTIMATED Volume	Corpus Christi Water Cost	Corpus Christi Price Per 1000g
October-23	46,684,537	\$108,808	\$2.330702
November-23	43,766,555	\$102,067	\$2.332082
December-23	43,175,347	\$100,702	\$2.332396
January-24	42,175,113	\$117,792	\$2.792927
February-24	40,307,375	\$112,618	\$2.793980
March-24	44,582,382	\$124,460	\$2.791686
April-24	47,248,387	\$131,844	\$2.790444
May-24	48,784,163	\$136,099	\$2.789819
June-24	47,722,339	\$133,157	\$2.790245
July-24	52,377,013	\$146,051	\$2.788456
August-24	54,184,251	\$151,057	\$2.787840
September-24	44,825,407	\$125,133	\$2.791564

The *estimated* Total Monthly Water Rate per month is as follows:

Month	Handling Charge	Corpus Christi Price Per 1000g	Estimated Total Price Per 1000g
October-23	0.500000	\$2.330702	\$2.830702
November-23	0.500000	\$2.332082	\$2.832082
December-23	0.500000	\$2.332396	\$2.832396
January-24	0.500000	\$2.792927	\$3.292927
February-24	0.500000	\$2.793980	\$3.293980
March-24	0.500000	\$2.791686	\$3.291686
April-24	0.500000	\$2.790444	\$3.290444
May-24	0.500000	\$2.789819	\$3.289819
June-24	0.500000	\$2.790245	\$3.290245
July-24	0.500000	\$2.788456	\$3.288456
August-24	0.500000	\$2.787840	\$3.287840
September-24	0.500000	\$2.791564	\$3.291564

Out of District Customers shall pay an in lieu of taxes monthly charge based on the Customer's taxable
value and the adopted tax rate.

NOW, THEREFORE, BE IT RESOLVED that the Board of Directors of the South Texas Water Authority adopts the attached Fiscal Year 2024 Budget and above stated water rates as reviewed by the Board of Directors.

Duly adopted this 12th day of September, 2023.

JOSE GRAVELEY, PRESIDENT

ATTEST:

IMELDA GARZA, SECRETARY/TREASURER

ATTACHMENT 6

Resolution 23-23

SOUTH TEXAS WATER AUTHORITY

Resolution 23-23

RESOLUTION ADOPTING THE FISCAL YEAR 2024/TAX YEAR 2023 TAX RATE.

WHEREAS, the South Texas Water Authority Board of Directors has determined that it is necessary to levy and collect ad valorem taxes for the 2023 tax year, and

WHEREAS, the combined appraisal rolls of the South Texas Water Authority have been compiled by the Appraisal Districts in Nueces and Kleberg Counties, and

WHEREAS, South Texas Water Authority held a public hearing on a proposed tax rate for the tax year 2023 on September 12, 2023 at 5:30 p.m. at 2302 East Sage Road, Kingsville, Texas 78363.

NOW, THEREFORE, BE IT RESOLVED by the Board of Directors of the South Texas Water Authority that the following tax rate shall be levied for Fiscal Year 2024/Tax Year 2023:

\$0.058044 per \$100 of taxable value for the purposes of maintenance and operation

\$0.012330 per \$100 of taxable value for debt service

\$0.070374 total tax rate per \$100 of taxable value

Duly adopted this 12th day of September, 2023.

JOSE M. GRAVELEY, PRESIDENT

ATTEST:

IMELDA GARZA, SECRETARY/TREASURER

ATTACHMENT 7

Auditor Engagement Letter

Memo

To: South Texas Water Authority Board of Directors
From: John Marez, Exec Dir/Administrator
Date: September 8, 2023
Re: Engagement Letter-John Womack and Company-Fiscal Year 2023-24

Background:

Enclosed is a Letter of Engagement for Auditing Services with John Womack & Company, P.C. (Womack) for fiscal year ending September 30, 2023.

The engagement letter provides all communication that the AICPA (American Institute of Certified Public Accountants) designates as necessary for the auditor and client. The letter is practically matching last year's letter.

Analysis:

The engagement letter indicates the auditing services will be performed under \$10,000 as compared to last year's services in the amount of \$9,500, representing a potential increase. Based on the attached letter from Womack and Company we should expect to have the audit begin by December 5, 2023 and reports should be issued no later than January 26, 2024.

Staff Recommendation:

Approve the Letter of Engagement for Auditing Services with John Womack & Company, P.C. for fiscal year ending September 30, 2023.

Board Action:

Determine whether to approve the engagement letter from John Womack & Company, P. C. for FY 2023/24 audit services not to exceed the amount of \$10,000. Review and acknowledge Womack's letter outlining the various factors of the external audit.

Summary:

An independent and external audit is necessary to ensure that fiscal accountability and proper responsibilities are maintained.

Engagement letter was not available at time of posting agenda. It will be provided prior to board meeting.

JOHN WOMACK & CO., P.C.
CERTIFIED PUBLIC ACCOUNTANTS

JOHN L. WOMACK, CPA
MARGARET KELLY, CPA

P.O. BOX 1147
KINGSVILLE, TEXAS 78364
(361) 592-2671
FAX (361) 592-1411

August 07, 2023

To the Board of Directors
South Texas Water Authority
2302 East Sage Road
Kingsville, Texas 78363

We are pleased to confirm our understanding of the services we are to provide South Texas Water Authority for the year ended September 30, 2023.

Audit Scope and Objectives

We will audit the financial statements of the governmental activities, each major fund, and the aggregate remaining fund information, and the disclosures, which collectively comprise the basic financial statements of South Texas Water Authority as of and for the year ended September 30, 2023. Accounting standards generally accepted in the United States of America (GAAP) provide for certain required supplementary information (RSI), such as management's discussion and analysis (MD&A), to supplement South Texas Water Authority's basic financial statements. Such information, although not a part of the basic financial statements, is required by the Governmental Accounting Standards Board who considers it to be an essential part of financial reporting for placing the basic financial statements in an appropriate operational, economic, or historical context. As part of our engagement we will apply certain limited procedures to South Texas Water Authority's RSI in accordance with auditing standards generally accepted in the United States of America (GAAS). These limited procedures will consist of inquiries of management regarding the methods of preparing the information and comparing the information for consistency with management's responses to our inquiries, the basic financial statements, and other knowledge we obtained during our audit of the basic financial statements. We will not express an opinion or provide any assurance on the information because the limited procedures do not provide us with sufficient appropriate evidence to express an opinion or provide any assurance. The following RSI is required by GAAP and will be subjected to certain limited procedures, but will not be audited.

- 1) Management's Discussion and Analysis
- 2) Budgetary Comparison Schedules – General Fund.



We have also been engaged to report on supplementary information other than RSI that accompanies South Texas Water Authority's financial statements. We will subject the following supplementary information to the auditing procedures applied in our audit of the financial statements and certain additional procedures, including comparing and reconciling such information directly to the underlying accounting and other records used to prepare the financial statements or to the financial statements themselves, and other additional procedures in accordance with GAAS, and we will provide an opinion on it in relation to the financial statements as a whole in a report combined with our auditor's report on the financial statements.

- 1) Individual Fund Budgetary Comparison Schedules.
- 2) Supplementary Information Required by Texas Commission on Environmental Quality.

The objectives of our audit are to obtain reasonable assurance as to whether the financial statements as a whole are free from material misstatement, whether due to fraud or error; issue an auditor's report that includes our opinion about whether your financial statements are fairly presented, in all material respects, in conformity with GAAP; and report on the fairness of the supplementary information referred to in the second paragraph when considered in relation to the financial statements as a whole. Reasonable assurance is a high level of assurance but is not absolute assurance and therefore is not a guarantee that an audit conducted in accordance with GAAS will always detect a material misstatement when it exists. Misstatements, including omissions, can arise from fraud or error and are considered material if there is a substantial likelihood that, individually or in the aggregate, they would influence the judgment of a reasonable user made based on the financial statements.

Auditor's Responsibilities for the Audit of the Financial Statements

We will conduct our audit in accordance with GAAS and will include tests of your accounting records and other procedures we consider necessary to enable us to express such opinions. As part of an audit in accordance with GAAS, we exercise professional judgment and maintain professional skepticism throughout the audit.

We will evaluate the appropriateness of accounting policies used and the reasonableness of significant accounting estimates made by management. We will also evaluate the overall presentation of the financial statements, including the disclosures, and determine whether the financial statements represent the underlying transactions and events in a manner that achieves fair presentation. We will plan and perform the audit to obtain reasonable assurance about whether the financial statements are free of material misstatement, whether from (1) errors, (2) fraudulent financial reporting, (3) misappropriation of assets, or (4) violations of laws or governmental regulations that are attributable to the government or to acts by management or employees acting on behalf of the government.

Because of the inherent limitations of an audit, combined with the inherent limitations of internal control, and because we will not perform a detailed examination of all transactions, there is an unavoidable risk that some material misstatements may not be detected by us, even though the audit is properly planned and performed in accordance with GAAS. In addition, an audit is not designed to detect immaterial misstatements or violations of laws or governmental regulations that do not have a direct and material effect on the financial statements. However, we will inform the appropriate level of management of any material errors, fraudulent financial reporting, or misappropriation of assets that comes to our attention. We will also inform the appropriate level of management of any violations of laws or governmental regulations that come to our attention, unless clearly inconsequential. Our responsibility as auditors is limited to the period covered by our audit and does not extend to any later periods for which we are not engaged as auditors.

In connection with this engagement, we may communicate with you or others via email transmission. As emails can be intercepted and read, disclosed, or otherwise used or communicated by an unintended third party, or may not be delivered to each of the parties to whom they are directed and only to such parties, we cannot guarantee or warrant that emails from us will be properly delivered and read only by the addressee. Therefore, we specifically disclaim and waive any liability or responsibility whatsoever for interception or unintentional disclosure of emails transmitted by us in connection with the performance of this engagement. In that regard, you agree that we shall have no liability for any loss or damage to any person or entity resulting from the use of email transmissions, including any consequential, incidental, direct, indirect, or special damages, such as loss of revenues or anticipated profits, or disclosure or communication of confidential or proprietary information.

We will also conclude, based on the audit evidence obtained, whether there are conditions or events, considered in the aggregate, that raise substantial doubt about the government's ability to continue as a going concern for a reasonable period of time.

Our procedures will include tests of documentary evidence supporting the transactions recorded in the accounts, tests of the physical existence of inventories, and direct confirmation of receivables and certain assets and liabilities by correspondence with selected customers, creditors, and financial institutions. We will also request written representations from your attorneys as part of the engagement and they may bill you for responding to this inquiry.

Our audit of the financial statements does not relieve you of your responsibilities.

Audit Procedures—Internal Control

We will obtain an understanding of the government and its environment, including the system of internal control, sufficient to identify and assess the risks of material misstatement of the financial statements, whether due to error or fraud, and to design and

perform audit procedures responsive to those risks and obtain evidence that is sufficient and appropriate to provide a basis for our opinions. The risk of not detecting a material misstatement resulting from fraud is higher than for one resulting from error, as fraud may involve collusion, forgery, intentional omissions, misrepresentation, or the override of internal control. An audit is not designed to provide assurance on internal control or to identify deficiencies in internal control. Accordingly, we will express no such opinion. However, during the audit, we will communicate to management and those charged with governance internal control related matters that are required to be communicated under AICPA professional standards.

As part of this communication, we have not identified any significant risks of material misstatement. However, planning has not concluded, and modifications may be made. If new significant risks are identified after the date of this initial communication, for example during the course of fieldwork, we will communicate them to those charged with governance in a timely manner, in writing.

Audit Procedures—Compliance

As part of obtaining reasonable assurance about whether the financial statements are free of material misstatement, we will perform tests of South Texas Water Authority's compliance with the provisions of applicable laws, regulations, contracts, and agreements. However, the objective of our audit will not be to provide an opinion on overall compliance and we will not express such an opinion.

Other Services

We will also assist in preparing the financial statements, related notes and cash-to-accrual conversions (i.e. GASB 34 conversions) of South Texas Water Authority in conformity with accounting principles generally accepted in the United States of America based on information provided by you.

We will perform the services in accordance with applicable professional standards. The other services are limited to the financial statement services previously defined. We, in our sole professional judgment, reserve the right to refuse to perform any procedure or take any action that could be construed as assuming management responsibilities.

You agree to assume all management responsibilities for the financial statement preparation services, related notes and cash-to-accrual conversions (i.e. GASB 34 conversions) and any other nonattest services we provide; oversee the services by designating an individual, JoElla Wagner, with suitable skill, knowledge, or experience; evaluate the adequacy and results of the services; and accept responsibility for them.

Responsibilities of Management for the Financial Statements

Our audit will be conducted on the basis that you acknowledge and understand your responsibility for designing, implementing, and maintaining internal controls relevant to the preparation and fair presentation of financial statements that are free from material misstatement, whether due to fraud or error, including monitoring ongoing activities; for the selection and application of accounting principles; and for the preparation and fair presentation of the financial statements in conformity with accounting principles generally accepted in the United States of America with the oversight of those charged with governance.

Management is responsible for making drafts of financial statements, all financial records, and related information available to us and for the accuracy and completeness of that information (including information from outside of the general and subsidiary ledgers). You are also responsible for providing us with (1) access to all information of which you are aware that is relevant to the preparation and fair presentation of the financial statements, such as records, documentation, identification of all related parties and all related-party relationships and transactions, and other matters; (2) additional information that we may request for the purpose of the audit; and (3) unrestricted access to persons within the government from whom we determine it necessary to obtain audit evidence. At the conclusion of our audit, we will require certain written representations from you about the financial statements and related matters.

Your responsibilities include adjusting the financial statements to correct material misstatements and confirming to us in the management representation letter that the effects of any uncorrected misstatements aggregated by us during the current engagement and pertaining to the latest period presented are immaterial, both individually and in the aggregate, to the financial statements of each opinion unit taken as a whole.

You are responsible for the design and implementation of programs and controls to prevent and detect fraud, and for informing us about all known or suspected fraud affecting the government involving (1) management, (2) employees who have significant roles in internal control, and (3) others where the fraud could have a material effect on the financial statements. Your responsibilities include informing us of your knowledge of any allegations of fraud or suspected fraud affecting the government received in communications from employees, former employees, grantors, regulators, or others. In addition, you are responsible for identifying and ensuring that the government complies with applicable laws and regulations.

You are responsible for the preparation of the supplementary information in conformity with accounting principles generally accepted in the United States of America (GAAP). You agree to include our report on the supplementary information in any document that contains, and indicates that we have reported on, the supplementary information. You also

agree to include the audited financial statements with any presentation of the supplementary information that includes our report thereon. Your responsibilities include acknowledging to us in the representation letter that (1) you are responsible for presentation of the supplementary information in accordance with GAAP; (2) you believe the supplementary information, including its form and content, is fairly presented in accordance with GAAP; (3) the methods of measurement or presentation have not changed from those used in the prior period (or, if they have changed, the reasons for such changes); and (4) you have disclosed to us any significant assumptions or interpretations underlying the measurement or presentation of the supplementary information.

With regard to publishing the financial statements on your website, you understand that websites are a means of distributing information and, therefore, we are not required to read the information contained in those sites or to consider the consistency of other information on the website with the original document.

Limitation on Liability

In the unlikely event that differences concerning our services or fees should arise that are not resolved by mutual agreement, to facilitate judicial resolution and save time and expense of both parties, the Water Authority agrees to participate in mediation, under the Commercial Mediation Rules of the American Arbitration Association, before any claim is asserted.

In the event that John Womack & Co., P.C. is found to be negligent in provision of any services covered by this agreement which result in damage to the Water Authority, John Womack & Co., P.C.'s liability to the Water Authority will be limited to actual damages or losses incurred by the Water Authority. John Womack & Co., P.C. will not be liable to the Water Authority for any punitive damages.

Engagement Administration, Fees, and Other

We understand that your employees will prepare all cash, accounts receivable, or other confirmations we request and will locate any documents selected by us for testing. We will not undertake any accounting services (including but not limited to reconciliation of accounts and preparation of requested schedules) without obtaining approval through a written change order or additional engagement letter for such additional work. We will schedule the engagement based in part on deadlines, working conditions, and the availability of your key personnel. We will plan the engagement based on the assumption that your personnel will cooperate and provide assistance by performing tasks such as preparing requested schedules, retrieving supporting documents, and preparing confirmations. If, for whatever reason, your personnel are unavailable to provide the necessary assistance in a timely manner, it may substantially increase the work we have to do to complete the engagement within the established deadlines, resulting in an increase in fees over our original fee estimate.

The audit documentation for this engagement is the property of John Womack & Co., P.C. and constitutes confidential information. However, subject to applicable laws and regulations, audit documentation and appropriate individuals will be made available upon request and in a timely manner to cognizant agencies or its designee. We will notify you of any such request. If requested, access to such audit documentation will be provided under the supervision of John Womack & Co., P.C. personnel. Furthermore, upon request, we may provide copies of selected audit documentation to the cognizant agency or its designee. The cognizant agency or its designee may intend or decide to distribute the copies or information contained therein to others, including other governmental agencies.

John L Womack is the engagement partner and is responsible for supervising the engagement and signing the report or authorizing another individual to sign it. To ensure that John Womack & Co., P.C.'s independence is not impaired under the *AICPA Code of Professional Conduct*, you agree to inform the engagement partner before entering into any substantive employment discussions with any of our personnel.

We expect to begin our audit on approximately December 04, 2023 and to issue our reports no later than January 29, 2024.

Our audit engagement ends on delivery of our audit report. Any follow-up services that might be required will be a separate, new engagement. The terms and conditions of that new engagement will be governed by a new, specific engagement letter for that service.

Our fee for services will be approximately \$9,950 plus out-of-pocket costs (such as report reproduction, word processing, postage, travel, copies, telephone, confirmation service provider fees, etc.). Our invoices for these fees will be rendered each month as work progresses and are payable on presentation. The above fee is based on anticipated cooperation from your personnel and the assumption that unexpected circumstances will not be encountered during the audit. If significant additional time is necessary, we will discuss it with you and arrive at a new fee estimate before we incur the additional costs.

As an attest client, John Womack & Co., P.C. cannot retain your documents on your behalf. This is in accordance with the ET 1.295.143 of the *AICPA Code of Professional Conduct*. South Texas Water Authority is responsible for maintaining its own data and records.

You may request that we perform additional services not addressed in this engagement letter. If this occurs, we will communicate with you regarding the scope of the additional services and the estimated fees. We also may issue a separate engagement letter covering the additional services. In the absence of any other written communication from us documenting such additional services, our services will continue to be governed by the terms of this engagement letter.

Reporting

We will issue a written report upon completion of our audit of South Texas Water Authority's financial statements which will also address other information in accordance with AU-C 720, *The Auditor's Responsibilities Relating to Other Information Included in Annual Reports*. Our report will be addressed to management and those charged with governance of South Texas Water Authority. Circumstances may arise in which our report may differ from its expected form and content based on the results of our audit. Depending on the nature of these circumstances, it may be necessary for us to modify our opinions, add a separate section, or add an emphasis-of-matter or other-matter paragraph to our auditor's report, or if necessary, withdraw from this engagement. If our opinions are other than unmodified, we will discuss the reasons with you in advance.

If circumstances occur related to the condition of your records, the availability of sufficient, appropriate audit evidence, or the existence of a significant risk of material misstatement of the financial statements caused by error, fraudulent financial reporting, or misappropriation of assets, which in our professional judgment prevent us from completing the audit or forming an opinion on the financial statements, we retain the right to take any course of action permitted by professional standards, including declining to express an opinion or issue a report, or withdrawing from the engagement.

You have engaged us to include in our report a section that discusses key audit matters, if any, identified during our audit. Key audit matters are matters that are communicated or required to be communicated to those charged with governance that were, in the auditor's professional judgment, of most significance to the audit of the financial statements of the current period. Key audit matters may involve, among other things, areas of higher assessed risk of material misstatement or significant identified risks; areas that required significant auditor judgment, such as accounting estimates or other areas subject to a high degree of estimation uncertainty; or the effect of significant events or transactions in the current period. For each key audit matter identified in our report, our report will describe the primary reason(s) we designated it as a key audit matter, how it was addressed in the audit, and refer to the financial statement account(s) or disclosure(s) related to it. The communication of key audit matters does not alter in any way our opinion on the financial statements, taken as a whole. If our audit does not identify any key audit matters, our audit report will state that conclusion.

We appreciate the opportunity to be of service to South Texas Water Authority and believe this letter accurately summarizes the significant terms of our engagement. If you have any questions, please let us know. If you agree with the terms of our engagement as described in this letter, please sign the attached copy and return it to us.

Sincerely,

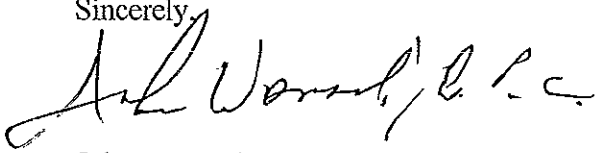
A handwritten signature in cursive script that reads "John Womack & Co., P.C." The signature is written in dark ink and is positioned above the printed name.

John Womack & Co., P.C.

RESPONSE:

This letter correctly sets forth the understanding of South Texas Water Authority.

Management signature: _____

Title: _____

Governance signature: _____

Title: _____

ATTACHMENT 8

Truck Bids

Memo

To: South Texas Water Authority Board of Directors
From: John Marez, Exec Dir/Admin
Date: September 8, 2023
Topic: Specifications for 2023 or 2024 a Half-ton Pickup Truck Replacement for Damaged 2019 Ford F-150 4x4 Truck

Background:

On June 26, 2023 a STWA Field Tech was in an accident with a High Boy tractor on FM 666 in Nueces County which appears to be a total loss for our vehicle. As anticipated our Texas Municipal League (TML) Insurance coverage reimbursed an estimated \$37,500 for a replacement STWA truck. However, based on last November's purchase of a model 2023 truck the actual cost of a similar vehicle will be upwards in the \$50,000 price range.

Analysis:

The provided spec sheet allows for an opportunity to review the accessories included with the purchase of a new truck and to authorize staff to proceed with the bidding process for a replacement vehicle once all insurance claims have been received.

Despite sending out bid packets to over 15 dealerships only one bid was received. That bid did not meet specifications the board authorized.

Staff Recommendation:

Reject current bids. Resubmit a new bid and take action on proposal by 9/26/2023 meeting to cover cost under the (Fiscal Year) FY 2022/23 Fiscal Budget.

Board Action:

(1) Reject Bid. (2) Authorize staff to solicit a new bid for a replacement STWA truck.

Summary:

Since the only bid submitted did not meet the specifications authorized by the board during the July 11, 2023 meeting and new bid process must preferably conclude prior to the end of the fiscal year. Bid recommendation will then be provided at the September 26th meeting, with Price, delivery, make/model to allow the board to make the most informed decision on the selection of the replacement STWA vehicle.



AutoNation Toyota

TOYOTA Corpus Christi

Date: 08/02/2023 3:25 PM Manager: David Wickwar
ID: 54191983 Associate: Tyrone Hobson

Customer: South Texas Water Authority
Address: 2302 East Sage Rd
KINGSVILLE, TX 78363

Phone: (361) 592-9323
Email: ngomez@stwa.org

VEHICLE



2023 Toyota Tundra 8242 SR 3.5L V6 (A10)
4x2 Double Cab 6.5 ft. box 145.7 in. WB
Stock #: PX30E578
Mileage: 10
VIN: 5TFKB5AA1PX30E578
Warranty: Manufacturer Warranty

BRAND PROMISE

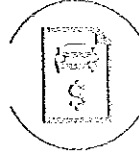

AutoNation Pricing
You'll see a low price, upfront, on every car, truck, and sport utility, so you'll save time and money.

PURCHASE OPTION

MSRP		\$42,119.00
AutoNation Savings	-	\$1,619.00
AutoNation Price		\$40,500.00
Sales Tax (estimate):	+	\$405.00
DealerDoc	+	\$150.00
Title Fee	+	\$33.00
INSPECTION TO STATE	+	\$16.75
License Fee	+	\$112.75
MISC (DEPUTY FEE)	+	\$5.00
Road and Bridge Fees	+	\$22.00
BUYER TAG FEES	+	\$5.00
INSPECTION TO STATION	+	\$7.00
VIT	+	\$83.96
Balance Due (estimate):		\$41,340.46

TRADE



We'll Buy Your Car
We provide a Guaranteed Trade-In Offer honored for 7 days or 500 miles at any of our locations.

Notes:
Ask how you can protect your vehicle tomorrow with a Vehicle Service Contract today! This menu is provided to you, our customer, to assist you in better understanding the financial options available. Appearance, Windshield, Theft and Dent Protection coverages are optional. Appearance Protection Products (fabric, leather and paint) have been pre-applied to the vehicle. Amounts above are ESTIMATES ONLY and may vary based on approved credit, applicable taxes, vehicle selection, trade value(s), estimated payoff, eligibility for rebates and other factors particular to your transaction. Final payments and terms may vary. Customer agrees to pay the difference, if any, in the amount of the trade in payoff.

X
Buyer: South Texas Water Authority
Date: 08/02/2023

X
Sales Manager
Date: 08/02/2023



AutoNation Toyota

TOYOTA Corpus Christi

Date: 08/02/2023 3:15 PM Manager: David Wickwar
ID: 54191983 Associate: Tyrone Hobson

Customer: South Texas Water Authority
Address: 2302 East Sage Rd
KINGSVILLE, TX 78363

Phone: (361) 592-9323
Email: ngomez@stwa.org

VEHICLE



2023 Toyota Tundra 8242 SR 3.5L V6 (A10)
4x2 Double Cab 6.5 ft. box 145.7 in. WB
Stock #: PX30E578
Mileage: 10
VIN: 5TFKB5AA1PX30E578
Warranty: Manufacturer Warranty

BRAND PROMISE

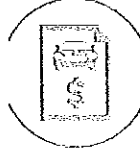

AutoNation Pricing
You'll see a low price, upfront, on every car, truck, and sport utility, so you'll save time and money.

PURCHASE OPTION

MSRP		\$42,119.00
AutoNation Savings	-	\$1,619.00
AutoNation Price		\$40,500.00
Sales Tax (estimate):	+	\$2,531.25
DealerDoc	+	\$150.00
Title Fee	+	\$33.00
INSPECTION TO STATE	+	\$16.75
License Fee	+	\$112.75
MISC (DEPUTY FEE)	+	\$5.00
Road and Bridge Fees	+	\$22.00
BUYER TAG FEES	+	\$5.00
INSPECTION TO STATION	+	\$7.00
VIT	+	\$83.96
Balance Due (estimate):		\$43,466.71

TRADE



We'll Buy Your Car
We provide a Guaranteed Trade-In Offer honored for 7 days or 500 miles at any of our locations.

Notes:

Ask how you can protect your vehicle tomorrow with a Vehicle Service Contract today! This menu is provided to you, our customer, to assist you in better understanding the financial options available. Appearance, Windshield, Theft and Dent Protection coverages are optional. Appearance Protection Products (fabric, leather and paint) have been pre-applied to the vehicle. Amounts above are ESTIMATES ONLY and may vary based on approved credit, applicable taxes, vehicle selection, trade value(s), estimated payoff, eligibility for rebates and other factors particular to your transaction. Final payments and terms may vary. Customer agrees to pay the difference, if any, in the amount of the trade in payoff.

X

Buyer: South Texas Water Authority

08/02/2023

Date

X

Sales Manager

08/02/2023

Date

SOUTH TEXAS WATER AUTHORITY

361-592-9323

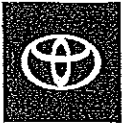

TOYOTA

AutoNation Toyota Corpus Christi
 6672 S. Padre Island Dr.
 Corpus Christi TX 78412
 361-444-0160

2023 TUNDRA

Tundra SR

Model: 8242
 VIN: 5TFKB5AA1PX30E578
 Stock: PX30E578
 Engine: i-FORCE V6
 Transmission: 10-speed automatic transmission



EXTERIOR Ice Cap INTERIOR Black Fabric

PRICE

Vehicle Base Model (MSRP *)	\$38,965.00
Factory Installed Packages & Accessories	\$555.00
Distributor Installed Packages & Accessories	\$704.00
Delivery Processing and Handling	\$1,895.00
Total Advertised Price	\$42,119.00

FUEL ECONOMY



INSTALLED PACKAGES & ACCESSORIES

50 State Emissions	FIO	\$0.00
SR Tow Package	FIO	\$555.00
SR Tow Package—includes Class-IV towing hitch receiver and wiring harness with 7-pin connector		
Charging and Connectivity Kit	LIO	\$205.00
Catalytic Converter Shield	LIO	\$499.00
Designed to deter theft of catalytic converters. Factory fit and clearance for routine maintenance. Strategically placed hardware and design to deter removal.		
Vehicle Fueling (10 gal.)	LIO	\$0.00
PDS - with Texas State Inspection	LIO	\$0.00
Total Optional Equipment		\$1,259.00
Vehicle Base Model		\$38,965.00
Delivery Processing and Handling		\$1,895.00

FEATURES

No Addons or sales tax

Mechanical & Performance

- i-FORCE 3.4L Twin-Turbo V6, 358 hp @ 5200 rpm, 406 lb.-ft. @ 2000 rpm
- Electronically Controlled Braking (ECB) system
- Ultra high-strength steel cabin construction with aluminum hood and front door panels
- Twin turbochargers with electric wastegate valve actuators and water-cooled intercooler
- 24-valve DOHC aluminum cylinder heads with Dual Variable Valve Timing with intelligence (VVT-i); 3445 c.c. aluminum engine block, 85.5 x 100 (mm.) bore x stroke, 10.4:1 compression ratio
- Stainless steel exhaust system
- Independent double-wishbone front suspension; coil spring multi-link rear suspension
- D-4ST direct-injection and port-injection fuel system
- Trailer-Sway Control (TSC)
- Low Emission Vehicle III (LEV-III)
- Engine: i-FORCE V6
- Weight Rating: 7035 lbs
- Rear-Wheel Drive (RWD) with Automatic Limited-Slip Differential (Auto LSD)
- Stop and Start Engine System (S&S)
- Electric Parking Brake (EPB)
- Power-assisted ventilated 13.9-in. front disc brakes with opposed dual-piston brake calipers; ventilated 13.6-in. rear disc brakes with single-piston calipers
- 10-speed Electronically Controlled automatic Transmission with intelligence (ECT-i), sequential shift mode, and uphill/downhill shift logic
- Electric Power Steering (EPS); power-assisted rack-and-pinion
- Engine and body undercovers
- Conventional 12V starter
- Fully boxed high-strength steel ladder frame with hydraulic cab mounts
- Rear-Wheel Drive (RWD) with Automatic Limited-Slip Differential (Auto LSD)
- 10-speed automatic transmission

Exterior

- 18-in. styled-steel wheels
- Black door handles, window molding, mirror caps and tailgate spoiler
- Heated power outside mirrors
- Washer-linked variable intermittent windshield wipers
- LED headlights with Daytime Running Lights (DRL), auto on/off feature, and manual leveling adjustment
- "TUNDRA" stamped easy lower and lift tailgate with smart switch release
- Black roof-mounted shark-fin antenna
- LED Trailer Reverse Assist (TRA) light
- Black horizontal-bar grille with black surround
- Deck rail header
- 6.5-ft. Standard Bed
- LED taillights
- LED center high-mount stop light (CHMSL) with integrated cargo lights
- Front door handles with touch-sensor lock/unlock feature
- Aluminum-reinforced composite bed construction

Interior

- Power horizontal rear window with defogger and privacy glass
- Day/night rearview mirror
- Polyurethane manual tilt/telescopic steering wheel with phone, audio, display/infotainment, and Driver Assist controls
- Combination meter with analog gauges and 4.2-in. color TFT Multi-Information Display (MID) with fuel economy, Driver Assist, vehicle/trip information, and warning messages
- Backup camera with projected path
- Front and rear LED maplights
- Front and rear assist grips
- Front 12V auxiliary power outlet
- 60/40 split, folding rear seat
- Single zone automatic climate control with air filtration
- Fabric-trimmed seats; 4-way manual adjustable driver and front passenger seats
- Rear under-seat storage compartment with removable and adjustable partitions
- Power windows with one-touch auto up/down and jam protection
- Fixed center console with gated shift lever, driving controls, four cup holders, and center storage bin
- Overhead console with rear window control, sunglasses storage and Safety Connect[®]
- Smart Key System with Push Button Start; remote keyless entry with lock, unlock, panic and tailgate release functions, and remote illuminated entry

Audio Multimedia

- 8-in. Toyota Audio Multimedia touchscreen with 6-speaker audio system, wireless Apple CarPlay[®] & Android Auto[™] compatible, SiriusXM[®] with 3-month Platinum Plan trial subscription. See toyota.com/audio-multimedia for details. ⁵

ToyotaCare

- No cost maintenance plan \$0 (No Cost)
- 24-hour Roadside Assistance \$0 (No Cost)

Safety & Convenience

- Hill Start Assist Control (HAC)
- Drive-Start Control (DSC)
- Toyota Safety Sense™ 2.5 Pre-Collision System with Pedestrian Detection, Full-Speed Range Dynamic Radar Cruise Control, Lane Departure Alert with Steering Assist, Lane Tracing Assist, Automatic High Beams, Road Sign Assist
- Eight total airbags, including driver and passenger side, knee and curtain airbags
- Driver and front passenger active headrests
- 3-point seatbelts for all seating positions; driver-side Emergency Locking Retractor (ELR) and Automatic/Emergency Locking Retractor (ALR/ELR) on all passenger seatbelts
- Star Safety System™— includes Vehicle Stability Control (VSC), Traction Control (TRAC), Anti-lock Brake System (ABS) with Electronic Brake-force Distribution (EBD), Brake Assist (BA) and Smart Stop Technology* (SST)
- Child-protector rear door locks and power window lockout control
- LATCH (Lower Anchors and Tethers for Children) includes lower anchors on all outboard second-row rear seats
- Safety Connect® — includes Emergency Assistance, Stolen Vehicle Locator, Roadside Assistance and Automatic Collision Notification. Available by subscription. Complimentary one-year trial subscription. (includes roof-mounted shark-fin antenna)
- Tire Pressure Monitor System (TPMS)

Connected Services

- Drive Connect — includes Cloud Navigation with Google Points of Interest (POI) data, Intelligent Assistant with Hey, Toyota, and Destination Assist. Subscription required after trial. 4G network dependent. Capable, subscription required
- Remote Connect — remotely interact with your vehicle through the Toyota app via your smartwatch. Depending on grade, allows you to lock/unlock doors, start and stop the vehicle, locate your last parked location, check vehicle status and monitor guest drivers. Subscription required after trial. 4G network dependent. 1-year trial subscription
- Service Connect — receive personalized maintenance updates and vehicle health reports. Subscription required after trial. 4G network dependent. Up to 10-year trial subscription
- Safety Connect® — includes Emergency Assistance button, enhanced Roadside Assistance, Automatic Collision Notification and Stolen Vehicle Locator. Subscription required after trial. 4G network dependent. Up to 10-year trial subscription
- Wi-Fi Connect — includes AT&T Wi-Fi hotspot and Integrated Streaming (Apple Music* and Amazon Music™) compatibility. Subscription required after trial. 4G network dependent. Up to 30-day/3 GB trial subscription

*2023 Manufacturer's Suggested Retail Price, excludes the Delivery, Processing and Handling Fee, taxes, license, title and available or regionally required equipment. Actual Dealer price may vary. Pricing, specifications, fuel economy, standard features and available equipment are based on information available when this page was produced and subject to change without notice.

ToyotaCare, which covers normal factory scheduled maintenance for 2 years or 25,000 miles, whichever comes first, is included as part of the sales price of the vehicle for qualifying buyers. See participating dealer for eligibility and coverage details.

Disclaimer: This document is only representative of some of the information contained on an actual window sticker, and is not meant to replace or substitute for the actual window sticker on the vehicle. Please see your retailer for further information.

Create Date: 03/02/2023

ATTACHMENT 9

Bids for Compact Track Loader

Memo

To: South Texas Water Authority Board of Directors
From: John Marez, Exec Dir/Administrator
Date: September 8, 2023
Re: Award Bid for Compact Track Loader – Fiscal Year 2022/23

Background:

On the July 28, 2023 meeting the board authorized the bid specifications for a Compact Track Loader “skid steer”. Specs were submitted to participating vendors and three bids were received.

Analysis:

The attached bids show three submissions with a low bid of \$76,066.56 All bids meet minimum specifications as approved by the board and outlines by staff.

The bid process was reviewed and cleared by our legal counsel.

Staff Recommendation:

Review and award a winning bid. Determine whether to proceed with the lowest bid.

Board Action:

Authorize the winning bid for Compact Track Loader.

Summary:

With Board approval of FY 2022/23 budget the purchase of a Compact Track Loader was approved as a Capital Investment purchase. The purchase of this equipment will allow field staff an additional option to work on emergency leaks, constructing new water lines and moving heavy loads of materials. This request also allows Operations and Maintenance (O&M) an additional tool to plan for and carry out more taps for new waterline accounts.



Distributor Name: Nueces Power Equipment
 Sales Person:
 Phone Number: 361-289-0066

Date: 8/24/2023

Price list date: 2/7/2023

Customer name: South Texas Water Authority
 Customer Contact:
 Customer Email:
 Customer PO#:
 PO Date

Model Discount: 25%
 Factor 75%

Machine Make	Model	Description	Sales Code	Factory List Price	Customer Price
CASE	TR270B	CTL	685-22	\$ 82,860.00	\$ 62,145.00
Ref. No.	Description				
	12.6" RUBBER TRACKS				\$ -
	72" LOW PROFILE BUCKET			\$ 2,076.00	\$ 1,557.00
	AIR RIDE SUSPENSION SEAT			\$ 669.00	\$ 501.75
	EH CAB LCD DISPLAY			\$ 5,771.00	\$ 4,328.25
	HYDRAULIC COUPLER			\$ 1,171.00	\$ 878.25
	DEMO FRONT DOOR			\$ 2,171.00	\$ 1,628.25
	AUX HYDRAULICS HIGH FLOW			\$ 3,425.00	\$ 2,568.75
	72" BOLT ON EDGE			\$ 383.00	\$ 287.25
	TELEMATICS CONNECTIVITY			\$ 1,000.00	\$ 750.00
Factory Options & Attachments					
Ref. No.	Description				
	Pallet forks				\$ 1,163.00
	NPE Discount				\$ (1,800.00)
Non-Factory Options & Attachments					
Ref. No.	Description				
	Warranty				\$ -
	Factory Freight				\$ 1,038.00
	Local Delivery				\$ 350.00
	PDI & Training				\$ 550.00
	Steel Surcharge				\$ -
Sub Total					\$ 75,945.50
Additional Discount/Trade In					0
Heavy Equipment Tax 0.00159					\$ 121.06
Total Sale Price					\$ 76,066.56
Validity	60 days				
Delivery	IN STOCK				
FOB	Customers Yard				



ENGINE	
Model	FPT F5H FL463 A*F001
Emissions Certification	Tier 4 Final
Type	Diesel 4-stroke, Turbo, D.I.
Cylinders	4
Bore/Stroke	3.9 x 4.3 in (99 x 110 mm)
Displacement	207 in ³ (3.4 L)
Fuel Injection	Direct, high pressure common rail – HPCR
Fuel	#2 Diesel
Fuel filter:	
Pre-filter	Beta (30) = 200/spin-on
Main filter	Beta (4) = 20/spin-on
Air intake	Turbocharged w/ waste gate and external cooled EGR
Exhaust aftertreatment	Particulate Matter Catalyst – PM Catalyst
Cooling	Liquid
Engine speeds	RPM
High idle – no load	2500 +/- 25
Rated – full load	2500
Low idle	1150 +/- 25
Horsepower @ 2500 RPM – SAE J1349:	
Gross	74 hp (55 kW)
Net	68 hp (51 kW)
Peak torque @ 1400 RPM	232 lb-ft (314 N·m)
Radiator:	
Core type	All aluminum
Core size area	2.77 ft ² (0.257 m ²)
Rows of tubes x columns	43 x 3
Cap pressure	16 +/- 2 psi (1.10 +/- 0.14 bar)
Fan:	
Diameter	20.4 in (518 mm)
Ratio	0.96:1 standard, 1.1:1 high-flow
Water pump:	
Style	Centrifugal
Flow	29 gpm (110 L/min)
Engine lubrication pump:	
Rotor pump w/ deep sump pan, plate cooler and pressurized under-piston nozzles	
Pump operating angle ratings:	
Side to side	45°
Bucket up	35°
Bucket Down	45°

LIFT GEOMETRY

Radial Lift

DRIVE TRAIN

Drive pump controls	Servo-assist mechanical
Pump to engine ratio	1:1
Displacement	2.81 in ³ (46 cm ³)
Flow @ rated engine RPM:	
@ 97% efficiency	29.4 gpm (111 L/min)
Charge pressure	360 psi (24.5 bar)
System relief pressure	5,220 psi (360 bar)

Drive pump controls	Electro-hydraulic
Pump to engine ratio	1:1
Displacement	2.75 in ³ (45 cm ³)
Flow @ rated engine RPM:	
@ 97% efficiency	28.8 gpm (109 L/min)
Charge pressure	362 psi (24.5 bar)
System relief pressure	5,220 psi (360 bar)

Drive motors:	
Max. displacement	3.10 in ³ (50.9 cm ³)
Displacement – optional:	
High speed	2.02 in ³ (33.1 cm ³)
Motor RPM @ high idle and 97% efficiency:	
Standard 1-speed	103
Optional 2-speed	156
Motor torque @ max. displacement and relief pressure, calculated @ 5,220 psi (360 bar):	4,654 lb-ft (6 310 N·m)

Travel speed:	
Low range	5.1 mph (8.2 kph)
High range – optional	7.6 mph (12.2 kph)

Final drive:	
Planetary gearbox w/ 2-speed motor	
Tractive effort	7,414 lb (3 370 kg)

Parking brake:	
Type	Spring-applied, hydraulic release multiple disc.
Engagement	Depress on/off brake button on handle or instrument panel, raise seat bar, get off seat or stop engine.

ELECTRICAL

Alternator	120 amp
Starter	4.29 hp (3.2 kW)
Battery	12-volt low-maintenance 925 cold-cranking amps @ 0° F (-18° C°)

OPERATOR ENVIRONMENT

ROPS/FOPS Level 1 canopy w/ side screens; Keyed start ignition; Tilt ROPS/FOPS; Rear window w/ emergency escape; Suspension Seat, vinyl w/ 2 in (51 mm) retractable 3 point lap seat belt; Hand and foot throttles; Alarm package – back-up and horn; Headliner; Dome Light; Top window; Cup holder; 12V Power plug socket; Foot rest; Seat pocket; Padded seat bar w/ integral armrests; Loader control lockout system; Electric parking brake control; Operator's compartment floor cleanout; Proportional

auxiliary hydraulic control – on joystick; Advanced Instrument Cluster w/ digital hour meter, tachometer, Fuel level LCD bar graph w/ alarm, diagnostic features and security lockout.

Warning lights with alarms:
Engine coolant temperature; Engine oil pressure; Engine malfunction; Hydraulic charge pressure; Hydraulic filter restriction; Hydraulic oil temperature: Critical system stop, Engine system, Hydraulic system, Electrical and diagnostic system.

Warning alarms:
Battery voltage – plus display; Oil service.

Indicator light:
Engine preheat; Parking brake;
Seat bar reminder.

OPERATING WEIGHT

Unit equipped w/ open cab; 165 lb operator;
72 in Dirt & Foundry bucket; full of fuel:
8,270 lb (3 750 kg)

Shipping weight 7,970 lb (3 615 kg)

Add-on weights:	
Side cab glass	47 lb (21.3 kg)
Polycarbonate cab door	74 lb (33.6 kg)
Glass cab door w/ wiper	134 lb (60.8 kg)
Suspension seat	22 lb (10.0 kg)
Additional counterweight	140 lb (63.8 kg)

HYDRAULICS

Implement pump type	Gear
Displacement:	
Standard aux.	2.23 in ³ (36.6 cm ³)
High-flow aux.	0.76 in ³ (12.5 cm ³)
Standard flow @ rated engine RPM: @ 100% efficiency	24.2 gpm (91.5 L/min)
Optional high-flow @ rated engine RPM: @ 100% efficiency	32.4 gpm (122.6 L/min)
Loader control valve:	
Type	3 spool/open center/series - series
Relief pressure	3,050 psi (210 bar)
Port relief pressures:	
Loader raise	3,263 psi (225 bar)
Bucket curl	3,770 psi (260 bar)
Bucket dump	1,160 psi (80 bar)
Hydraulic lines:	
Tubing	37° JIC Flare
Loop hoses	SAE 100 R19

Hydraulic oil cooler:	
Number of fins	10 per inch (3.94 per cm)
Number of tube rows x columns	9 x 1
Area	136.5 in ² (880 cm ²)
Hydraulic filter	Beta (4) = 75/spin-on

HYDRAULICS CONT.

Lift cylinders:	
Bore diameter	2.50 in (63.5 mm)
Rod diameter	1.75 in (44.5 mm)
Stroke	31.69 in (804.9 mm)
Closed length	45.59 in (1 158.0 mm)

Bucket cylinders:	
Bore diameter	2.75 in (69.9 mm)
Rod diameter	1.38 in (34.9 mm)
Stroke	16.14 in (410.0 mm)
Closed length	24.02 in (610.0 mm)

SERVICE CAPACITIES

Fuel Tank	19.5 gal (73.8 L)
Engine oil w/ filter	10.0 qt (9.4 L)
Hydraulic system:	
Reservoir	7.0 gal (26.5 L)
Total	8.5 gal (32.2 L)

PERFORMANCE SPECS

Rated operating capacity – ROC*:	
35% of tipping load	1,890 lb (860 kg)
50% of tipping load	2,700 lb (1 225 kg)
w/ additional counterweight	2,800 lb (1 270 kg)
Tipping load*	5,400 lb (2 449 kg)
Breakout forces @ 3,150 psi (217 bar)*:	
Bucket cylinders	7,270 lb (32.3 kN)
Lift cylinders – hydraulic limit	6,260 lb (27.8 kN)
Cycle times:	
Raise	3.6 sec
Lower	1.8 sec
Dump	2.2 sec
Roll back	1.7 sec

NOTE: *Measured using 72 in (1.83 m) foundry/ excavating bucket.

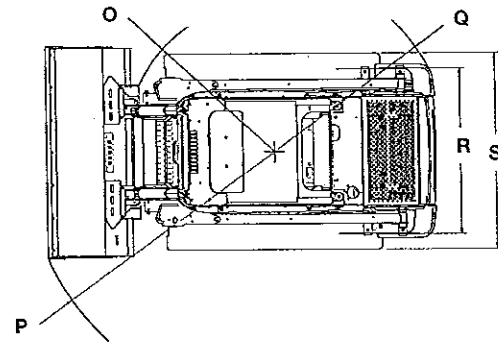
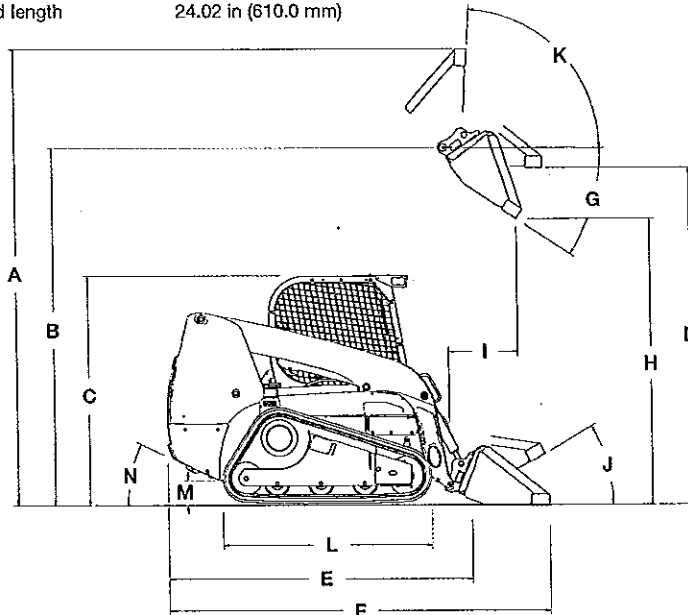

Line drawings are for illustrative purpose only and may not be exact representation of unit.

DIMENSIONS

A. Overall operating height:	
with foundry/excavating bucket	154.3 in (3.92 m)
with low profile bucket	158.3 in (4.02 m)
with low profile extended bucket	163.2 in (4.15 m)
Height to:	
B. Bucket hinge pin	123.0 in (3.12 m)
C. Top of ROPS	78.7 in (2.00 m)
D. Bottom of level bucket, fully raised	116.1 in (2.95 m)
Overall length:	
E. without attachment with coupler	105.1 in (2.67 m)
F. with foundry/excavating bucket on ground	129.6 in (3.29 m)
with low profile bucket	133.7 in (3.40 m)
with low profile extended bucket	138.8 in (3.53 m)
G. Maximum dump angle	39.6°
H. Dump height:	
with foundry/excavating bucket	98.2 in (2.50 m) @ 39.6°
with low profile bucket	95.6 in (2.43 m) @ 39.6°
I. Dump reach at maximum height with low profile bucket	25.4 in (0.65 m) @ 39.6°
Maximum attachment rollback:	
J. Bucket on ground	31.0°
K. Bucket at full height	98.6°
L. Track on ground	55.9 in (1.42 m)
M. Ground clearance – bottom of belly pan	8.0 in (0.20 m)
N. Angle of departure	32.0°
Clearance circle:	
O. without bucket	50.7 in (1.29 m)
P. with 72 in (1.83 m) foundry/excavating bucket in carry position	79.9 in (2.03 m)
with 72 in (1.83 m) low profile bucket on ground	83.1 in (2.11 m)
with 72 in (1.83 m) extended low profile on ground	87.7 in (2.23 m)
Q. Clearance circle rear	62.9 in (1.60 m)
R. Track gauge	53.4 in (1.36 m)
S. Over the track width	65.9 in (1.68 m)

TRACK SELECTION

Type	Area	Ground Pressure	Width to Outside Track
12.6 in (320 mm)	1,408 in ² (9 100 cm ²)	5.9 psi (40.5 kPa)	65.9 in (1.68 m)

OPTIONAL BUCKETS

Type	Width	Weight	Heaped Capacity
Dirt & Foundry	72 in (1.83 m)	420 lb (190 kg)	16.2 ft ³ (0.46 m ³)
	78 in (1.98 m)	440 lb (200 kg)	17.7 ft ³ (0.50 m ³)
Low Profile	72 in (1.83 m)	480 lb (218 kg)	14.8 ft ³ (0.42 m ³)
	72 in (1.83 m)	510 lb (232 kg)	17.7 ft ³ (0.50 m ³)
	78 in (1.98 m)	540 lb (245 kg)	19.1 ft ³ (0.54 m ³)
Low Profile Extended	84 in (2.13 m)	575 lb (262 kg)	20.5 ft ³ (0.58 m ³)
	72 in (1.83 m)	475 lb (216 kg)	23.3 ft ³ (0.66 m ³)
Light Material	84 in (2.13 m)	540 lb (245 kg)	27.5 ft ³ (0.78 m ³)
	72 in (1.83 m)	480 lb (218 kg)	19.1 ft ³ (0.54 m ³)
Manure & Slurry	84 in (2.13 m)	545 lb (248 kg)	22.6 ft ³ (0.64 m ³)
	72 in (1.83 m)	510 lb (230 kg)	14.1 ft ³ (0.40 m ³)
Heavy-Duty	78 in (1.98 m)	530 lb (240 kg)	15.5 ft ³ (0.44 m ³)
	72 in (1.83 m)	585 lb (265 kg)	18.4 ft ³ (0.52 m ³)
Heavy-Duty with spillguard	78 in (1.98 m)	605 lb (275 kg)	19.8 ft ³ (0.56 m ³)

STANDARD EQUIPMENT**OPERATION ENVIRONMENT**

See page 1

ENGINE

FPT F5H FL463 A*F001
 207 CID (3.4 L) Turbo
 Tier 4 Final Certified
 Particulate Matter Catalyst
 High Pressure Common Rail (HPCR)
 fuel injection
 Horsepower:
 Gross: 74 hp (55 kW)
 Net: 68 hp (51 kW)
 Peak torque 232 lb-ft (314 N·m)
 120 amp alternator
 Dual element air cleaner
 Organic Acid Technology (OAT)
 Anti-freeze solution to -34° F
 Fuel tank - 19.5 gal (U.S.)
 Over and under radiator and oil cooler
 3-stack after cooler/radiator/oil
 cooler configuration
 Glow plugs
 Integral engine oil cooler
 Fuel filter with water trap
 1,000 CCA 12V battery
 Master electrical disconnect

DRIVE TRAIN

2-speed hydrostatic four wheel drive
 SAHR disc parking brake

HYDRAULICS

Auxiliary hydraulics:
 @ 3,050 psi (210 bar) - 24.2 gpm
 (91.5 L/min)
 6 micron oil filtration system
 3-spool loader control valve
 Auxiliary hydraulic disconnects, ISO
 flat-face - connect-under-pressure
 with case drain
 Hydraulic circuit pedal lock
 Auxiliary function lockout override
 Loader lift lockout override
 Heavy-duty hydraulic oil cooler
 Loader arm float position
 Loader function lockout system
 Hydraulic one-way self-leveling
 Ride control

LOADER

Manual attachment coupler
 Radial lift geometry
 Loader lift arm support strut
 SAE operating load: 2,700 lbs
 Tipping load: 5,400 lbs

TRACKS

HiQual S-Wave Tracks

OTHER STANDARD FEATURES

Halogen lights - 2 front, 2 side, 2 rear flood
 Heavy duty front lights
 Pre-wired for rotating beacon
 Lockable service access hood
 Single-point daily servicing
 Rear tail lights
 Remote oil drain
 Remote oil and fuel filters
 Block heater
 Debris ingress sealing
 Mounting points for add-on counterweights

OPTIONAL EQUIPMENT

OPERATOR ENVIRONMENT

Enclosed cab:

- Fully sealed and pressurized – FSP
- Glass door with wiper and washer
- Sliding side windows – removable
- Ventilation system with integrated heater
- Heater and air conditioner
- AM/FM radio with 2 speakers
- Keyless start ignition

Electro-hydraulic controls:

- For drive/steering, loader functions
- Switchable between H and ISO patterns
- Adjustable sensitivity of controls

Mechanical hand controls

Hand and foot controls:

- Hand controls the loader drive function and foot controls the bucket and boom

Non suspension seat

- Deluxe cloth, air suspension seat, with heater and lumbar support

Open cab interior trim package

Demolition cab door with polycarbonate

FOPS Level 2

Heavy duty rear Door

HYDRAULICS

- High-flow auxiliary hydraulics – combined:
 - @ 3,050 psi (210 bar) – 32.4 gpm (122.6 L/min)
- Second auxiliary hydraulics

LOADER

- Auxiliary front electric control
- Hydraulic attachment coupler

OTHER

- Language decals
- Factory-installed tires – see page 3
- Buckets – see page 3
- Bolt-on bucket cutting edges
- Bolt-on heavy-duty bucket spill guard
- Special paint
- Offsite service arrangement
- Telematics

FACTORY SUPPLIED ATTACHMENTS

- Interior mirror
- Add-on counterweights
- Road lights
- Rotating beacon
- Four-corner LED strobe
- Bolt-on heavy-duty bucket teeth
- 48 in (1.22 m) pallet forks

SERVICE PARTS

- 3 Inch (76.2 mm) retractable seat belt

CaseCE.com

©2017 CNH Industrial America LLC. All rights reserved. CASE is a trademark registered in the United States and many other countries, owned by or licensed to CNH Industrial N.V., its subsidiaries or affiliates. CNH Industrial Capital is a trademark in the United States and many other countries, owned by or licensed to CNH Industrial N.V., its subsidiaries or affiliates. Printed in U.S.A. Contains 10% post-consumer fiber.

IMPORTANT: CASE Construction Equipment Inc. reserves the right to change these specifications without notice and without incurring any obligation relating to such change. Availability of some models and equipment builds vary according to the country in which the equipment is used. The illustrations and text may include optional equipment and accessories and may not include all standard equipment. Your CASE dealer/distributor will be able to give you details of the products and their specifications available in your area.



CASE Construction Equipment is biodiesel-friendly. NOTE: All engines meet current EPA emissions regulations. All specifications are stated in accordance with SAE Standards or Recommended Practices, where applicable.



Always read the Operator's Manual before operating any equipment. Inspect equipment before using it, and be sure it is operating properly. Follow the product safety signs and use any safety features provided.

Form No. GCE201702TR270
Replaces Form No. GCE201608TR270T4

TR270

4K Heavy Duty Pallet Fork Frame	7294305	1	446.88	446.88
48" 4K Heavy Duty Pallet Fork Teeth	6540182	1	340.48	340.48
Total for T76 T4 Bobcat Compact Track Loader				76,836.37

Quote Total - USD	76,836.37
Dealer P.D.I.	200.00
Freight Charges	1,675.00
Destination Charges	323.00
Dealer Assembly Charges	85.00
Quote Total - USD	79,119.37

Comment:

*Plus applicable taxes. IF Tax Exempt, please include Tax Exempt Certificate with the order.

*Prices per the Texas Buyboard Construction Equipment Contract #685-22.

*All orders should include 1) Accounts Payable Contact and email address, 2) W9 with correct legal entity name, and 3) Bill to Address.

*Orders may be placed with the contract holder or authorized dealer as allowed by the terms and conditions of the contract. *A Copy of all orders must be provided to Heather.Messmer@Doosan.com.

*Contact Holder Information: Clark Equipment Company dba Bobcat Company, Govt Sales, 250 E Beaton Drive, West Fargo, ND 58078. TID# 38-0425350.

*Payment Terms: Net 60 Days. Credit cards accepted.

*Remittance address: Clark Equipment Company d/b/a Bobcat Company, P. O. Box 74007382, Chicago, IL 60674-7382

*Questions can be submitted via email to Jesse.Rheault@doosan.com or by phone at: 1-800-965-4232.

Customer Acceptance:

Quotation Number: NC45676

Purchase Order: _____

Authorized Signature:

Print: _____ Sign: _____

Date: _____ Email: _____

Addresses:

Delivery Address: _____

Billing Address (if different from ship to): _____

Tax Exempt: Y / N

Exempt in the State of: _____

Tax Exempt ID:

Federal: _____

State: _____

Expiration Date: _____

HOLT.

DATE: Aug 21, 2023

QUOTE #:324284-01

SOUTH TEXAS WATER AUTHORITY
 OSCAR ORTEGON
 P.O. BOX 1701
 KINGSVILLE, TEXAS 78364

Rodriguez, Leonel
 361.813.1626

One (1) New Caterpillar Inc Model: 249D CAB Compact Construction Equipment with all standard equipment in addition to the additional specifications listed below:

STOCK NUMBER: HL2000252

SERIAL NUMBER: 0WKD00215

YEAR: 2023

HOURS: 3

SALE PRICE	\$71,463.15
EXT WARRANTY	Included
TOTAL PRICE	\$71,463.15
<hr/>	
SUB TOTAL	\$71,463.15
SALES TAX (8.25%)	\$5,895.71
HET (0.21%)	\$150.07
TERP (1.5%)	\$1,071.95
TOTAL TAXES	\$7,117.73
TOTAL PURCHASE PRICE	\$78,580.88

WARRANTY

Standard Warranty: 24 Month/2000 Hour Total Machine Limited Warranty
 Extended Warranty: 48 MO/3000 HR PREMIER

MACHINE SPECIFICATIONS

STOCK NUMBER: HL2000252

SERIAL NUMBER: 0WKD00215

YEAR: 2023

HOURS: 3

DESCRIPTION	REF.#
249D3 COMPACT TRACK LOADER	568-4729
LANE 3 ORDER	0P-9003
CAB PACKAGE, PRO	596-2954
TRACK,RUBBER,320MM(12.6IN)BLCK	420-9890
RIDE CONTROL, NONE	421-0016
BATTERY,HD,DISCONNECT, 850 CCA	579-2412
REAR LIGHTS	356-6082
DOOR, CAB, GLASS	545-6277
SEAT BELT, 2"	542-6994
PRODUCT LINK, CELLULAR PL243	566-7115
HYDRAULIC OIL, STANDARD	601-4753
CERTIFICATION ARR, P65	563-1163
INSTRUCTIONS, ANSI, USA	512-4447
INSTRUCTIONS, ENGLISH	580-1439
PACKING, ROLL ON - ROLL OFF	0P-0226
BUCKET-GP, 74", BOCE	279-5373
CARRIAGE, 46", FORKS, 48", SSL	353-1697
KIT, COUNTERWEIGHT, 100 LB ROC	388-7875

CAT 568-4729 249D3 COMPACT TRACK LOADER

**THE NEW D3 Series
SSL/CTL**

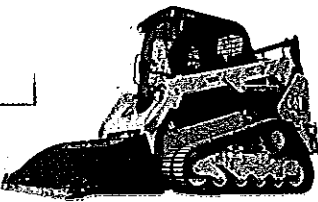



COMFORTABLE. PERFORMANCE. SMART.
CUSTOMER-DRIVEN COMFORT, PERFORMANCE, AND TECHNOLOGY ENHANCEMENTS.

15% ADDITIONAL SPACE FOR MORE OPERATOR COMFORT

- Redesigned, More Comfortable Cab
- Wider opening door for easier machine entry

PERFORMANCE

- Improved Performance-Tuned Suspension
- Custom Driven Enhancements to Fuel System & Drive Train

SMART

- Providing the Next Level Machine and Tool Compatibility
- Integrated SMART technology in a diverse complex attachments—INDUSTRY FIRSTS
 - Attachment recognition
 - Tabor control
 - Grade Assist

© 2023 Caterpillar Inc. All rights reserved. CAT, the Caterpillar logo and the "Caterpillar" name are trademarks of Caterpillar Inc. in the United States and other countries. All other marks are the property of their respective owners.

STANDARD EQUIPMENT

POWERTRAIN

Cat C2.2TA DI diesel engine
-Gross horsepower per SAE J1349
67 hp (50 kW) @ 2800 RPM
-Electric fuel priming pump
-Glow plugs starting aid
-Liquid cooled, direct injection
Air cleaner, dual element, radial seal
S-O-S sampling valve, hydraulic oil

Filter, cartridge type, hydraulic
Filters, canister type, fuel
and water separator
Radiator / hydraulic oil
cooler (side-by-side)
Spring applied, hydraulically released,
parking brakes
Hydrostatic transmission

UNDERCARRIAGE

Dual flange front idler
Single flange rear idler

Suspension - independent torsion axle(4)
Two speed motor

HYDRAULICS

ISO or H pattern controls:
Electro/hydraulic implement control

Electro/hydraulic hydrostatic
transmission control

ELECTRICAL

12 volt electrical system
80 ampere alternator
Ignition key start / stop / aux switch
Lights:
-LED work lights (2 front, 2 rear)

-Gauge backlighting
-Two rear tail lights
-Dome light
Backup alarm
Electrical outlet, beacon

OPERATOR ENVIRONMENT

Operator warning system indicators:
-Air filter restriction
-Alternator output
-Armrest raised / operator out of seat
-Engine coolant temperature
-Engine oil pressure

-Glow plug activation
-Hydraulic filter restriction
-Hydraulic oil temperature
-Park brake engages
-Engine emission system
Gauges: fuel level and hour meter

OTHER STANDARD EQUIPMENT

Engine enclosure - lockable
Extended life antifreeze (-37C, -34F)
Coupler, mechanical
Hydraulic oil level sight gauge
Radiator coolant level sight gauge
Radiator expansion bottle
Cat ToughGuard TM hose

Heavy duty flat faced quick disconnects
Split D-Ring to Route Work Tool Hoses
along side of left lift arm
Variable speed hydraulic cooling fan
Per SAE J818-2007 and EN 474-3:2006 and
ISO 14397-1:2007

FRAMES

Rear bumper, welded
Support, lift arm
Belly pan cleanout

Machine tie down points (6)
Chassis, one piece welded
Lift linkage, vertical path

OPERATOR ENVIRONMENT

Hand (dial) throttle, electronic
Horn
USB charging port
Interior rear view mirror
Floor mat
Top and rear windows
FOPS, Level I
Keypad
Anti-theft security system w/6-button

ROPS Cab, open, tilt up
-Parking brake engages
-Hydrostatic transmission disables
-Hydraulic system disables
leaves seat or armrest raised :
Control interlock system, when operator
Adjustable joystick controls
Ergonomic contoured armrest
Storage compartment with netting

ATTACHMENT 10

Resolution 23-24

SOUTH TEXAS WATER AUTHORITY

RESOLUTION 23-24

RESOLUTION AWARDING THE BID FOR THE PURCHASE OF ONE COMPACT TRACK LOADER.

WHEREAS, the South Texas Water Authority solicited bids to acquire one compact track loader for the Authority's use, and

WHEREAS, the Board of Directors of the South Texas Water Authority has reviewed the bids and finds that _____ has submitted the lowest responsible bid.

NOW, THEREFORE, BE IT RESOLVED that the South Texas Water Authority Board of Directors awards the bid for one compact track loader.

Duly adopted this 12th day of September, 2023.

JOSE M. GRAVELEY, PRESIDENT

ATTEST:

IMELDA GARZA, SECRETARY/TREASURER